

# Conference Table



2 person  
assembly



300 lbs  
(136 kg)

**vari**<sup>®</sup>

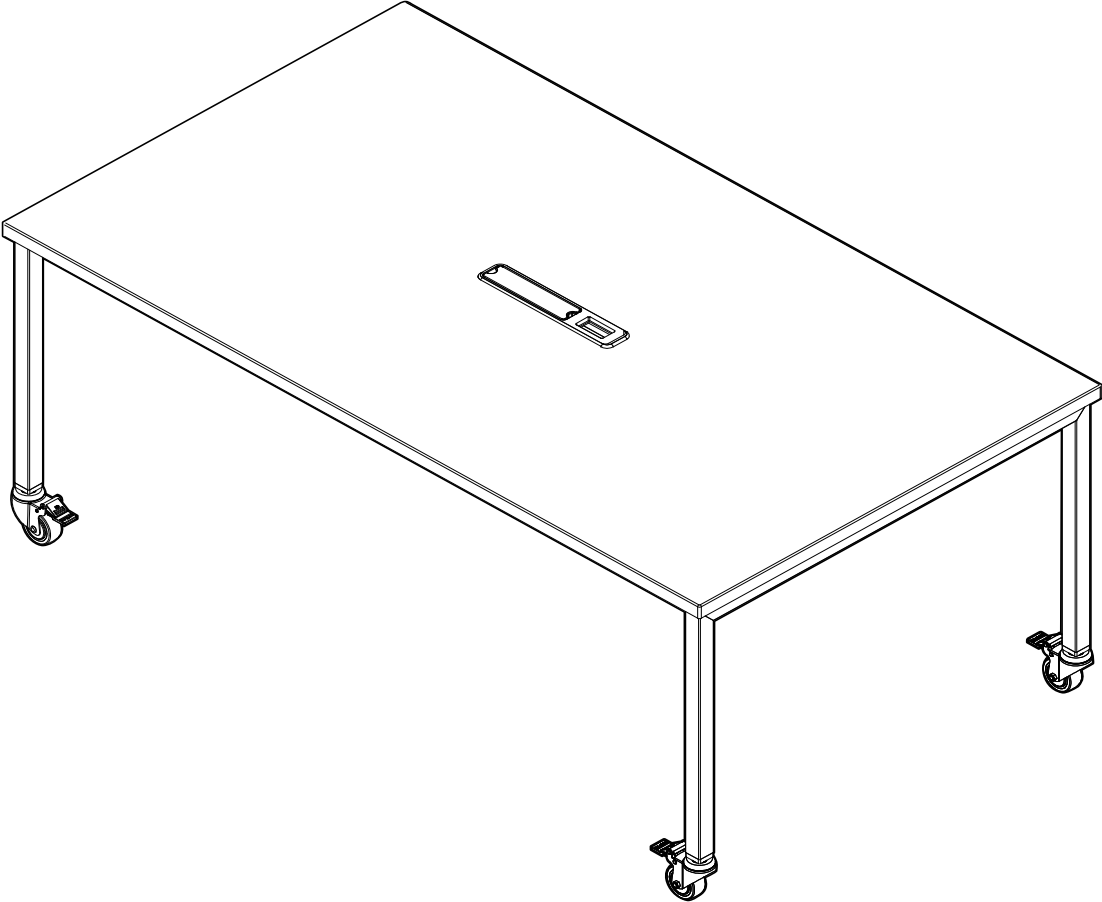

# Included Parts

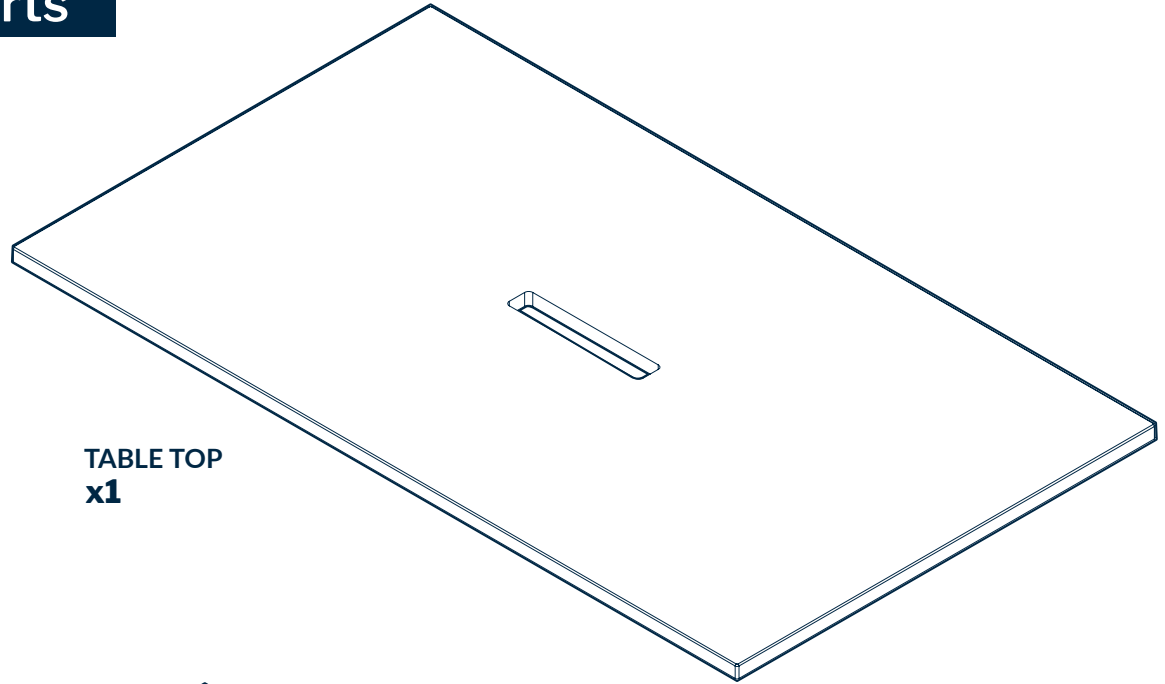

TABLE TOP  
x1

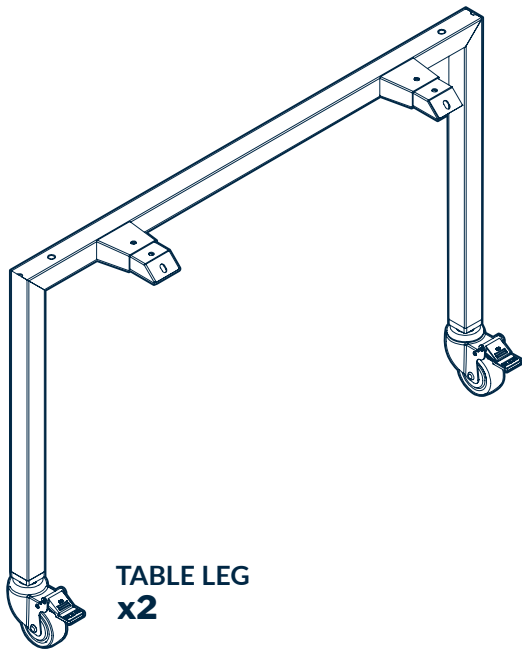
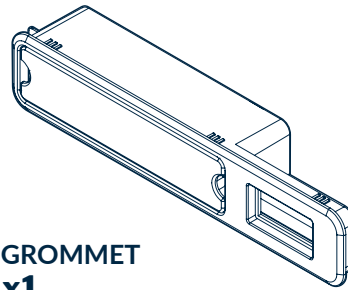

TABLE LEG  
x2



GROMMET  
x1



M4 X 6MM  
SCREW  
x3

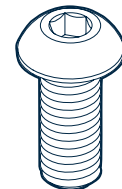

M8 X 20MM  
SCREW  
x16

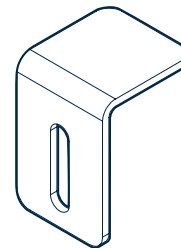

ANGLE  
BRACKET  
x3



5MM ALLEN KEY  
x1



M8 FLAT  
WASHER  
x20

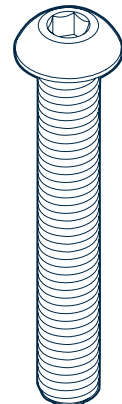

M8 X 55MM  
SCREW  
x4



M8 LOCK  
WASHER  
x20

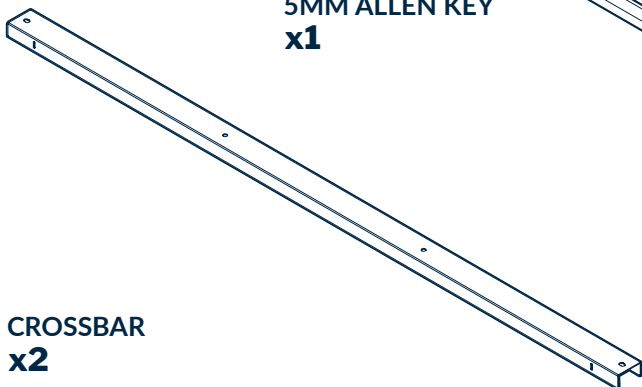

CROSSBAR  
x2

1

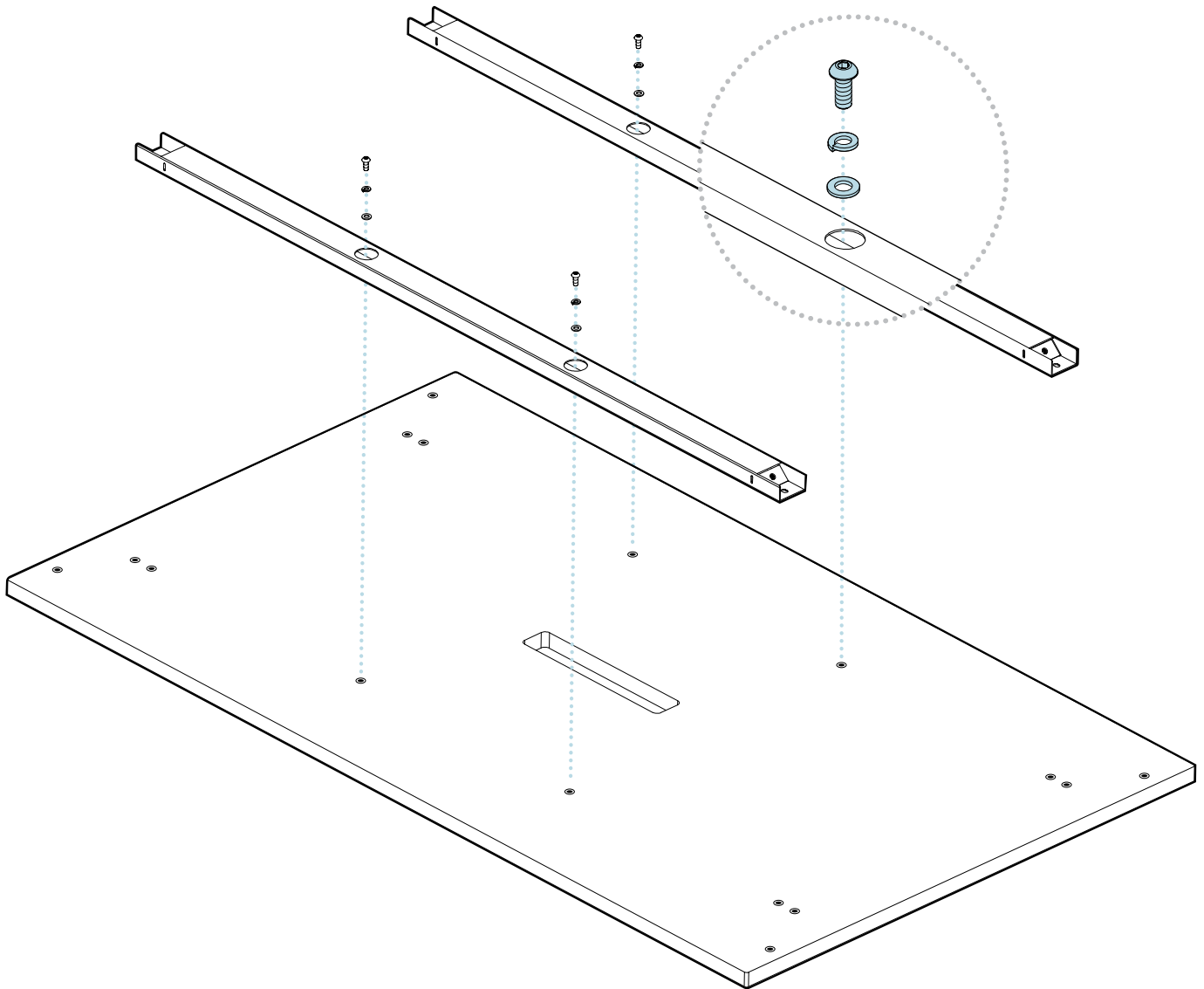

To prevent any surface scratching we recommend assembling the table in its box ( or on another smooth, debris-free flat surface.) With the tabletop face-down and frame-up, align the two **CROSSBARS** with the insert holes on the table top. Place an **M8 LOCK WASHER** and a **M8 FLAT WASHER** onto each of the **M8 x 20 SCREWS**, forming four sets. Insert each set into the opening in each **CROSSBAR**, and use the provided **5MM ALLEN KEY** to secure them to the top.

2

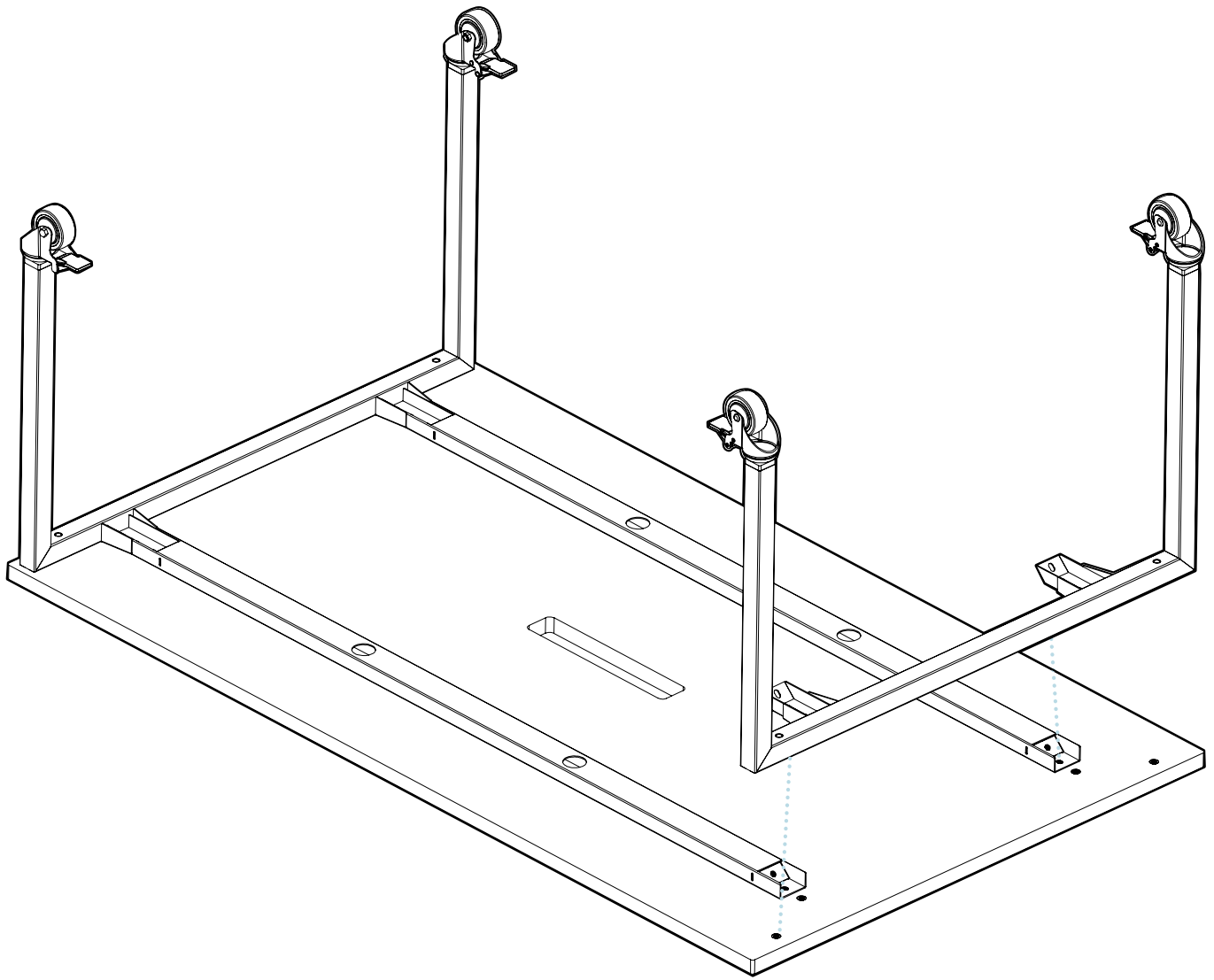

Lower the **LEGS** onto the table top, and align the leg frame inserts with the table top **CROSSBAR** cutouts.

3

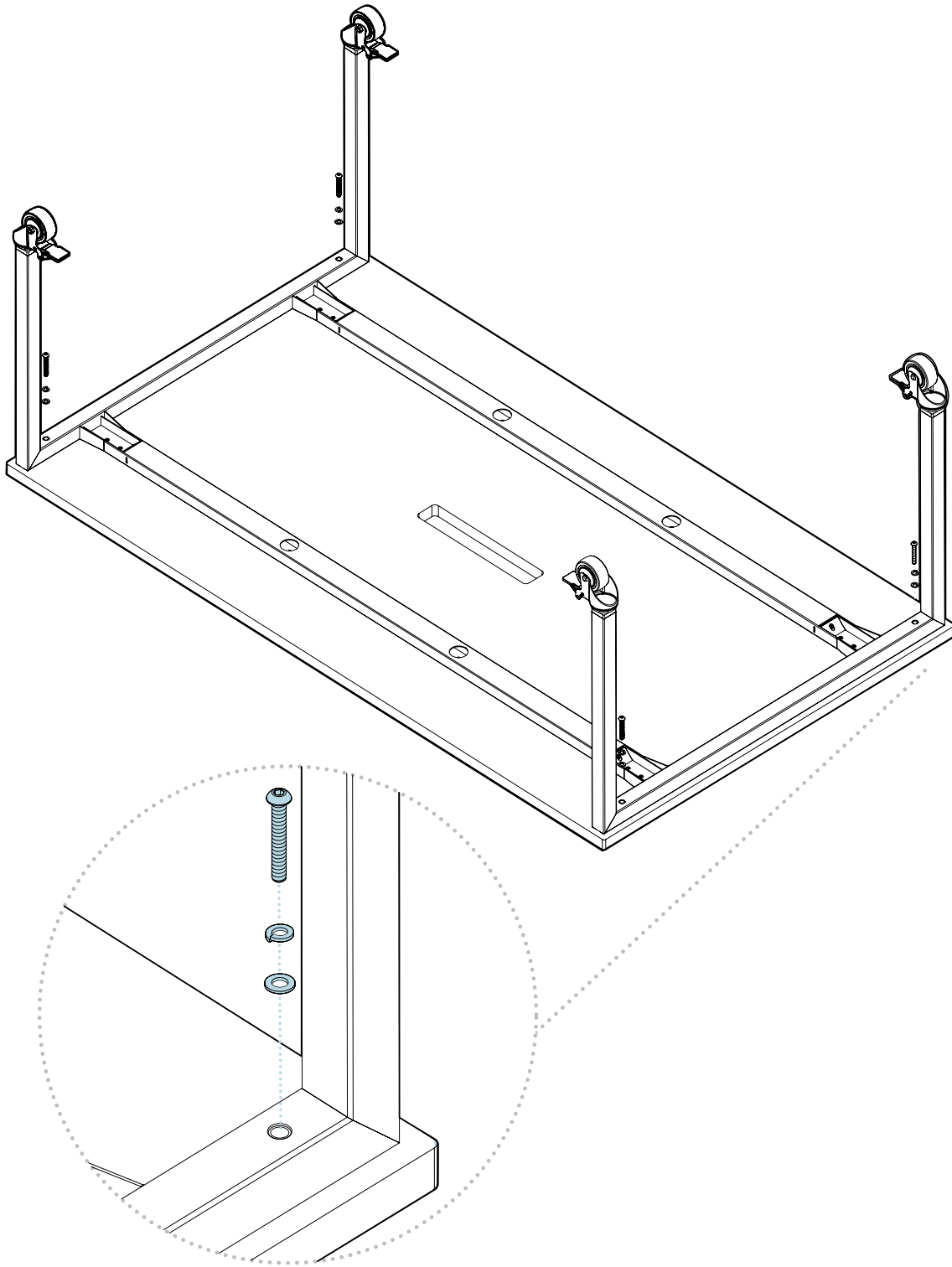

Place an **M8 LOCK WASHER** and then an **M8 FLAT WASHER** onto each of the **M8 x 55MM SCREWS**, forming (4) sets. Insert each set into an opening in a corner of each leg frame, and use the provided **5MM ALLEN KEY** to partially secure them to the table top.

4

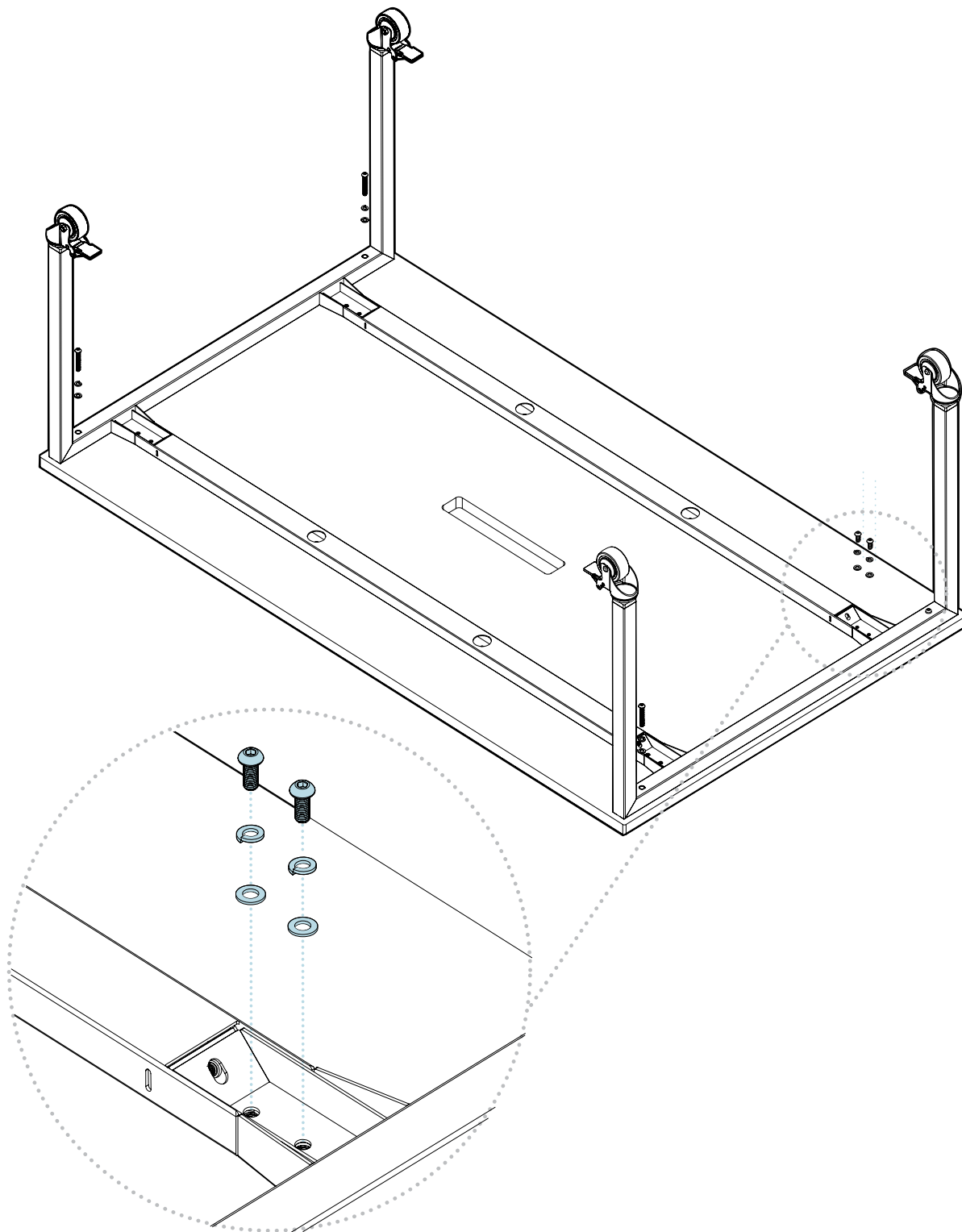

Place a **LOCK WASHER** and then a **FLAT WASHER** onto (8) of the **M8 x 20MM SCREWS**, forming eight sets. Insert each set into a flat opening where the leg frame inserts meet the table top frame. Use the provided **5MM ALLEN KEY** to secure the leg frame inserts to the top **CROSSBARS**.

5

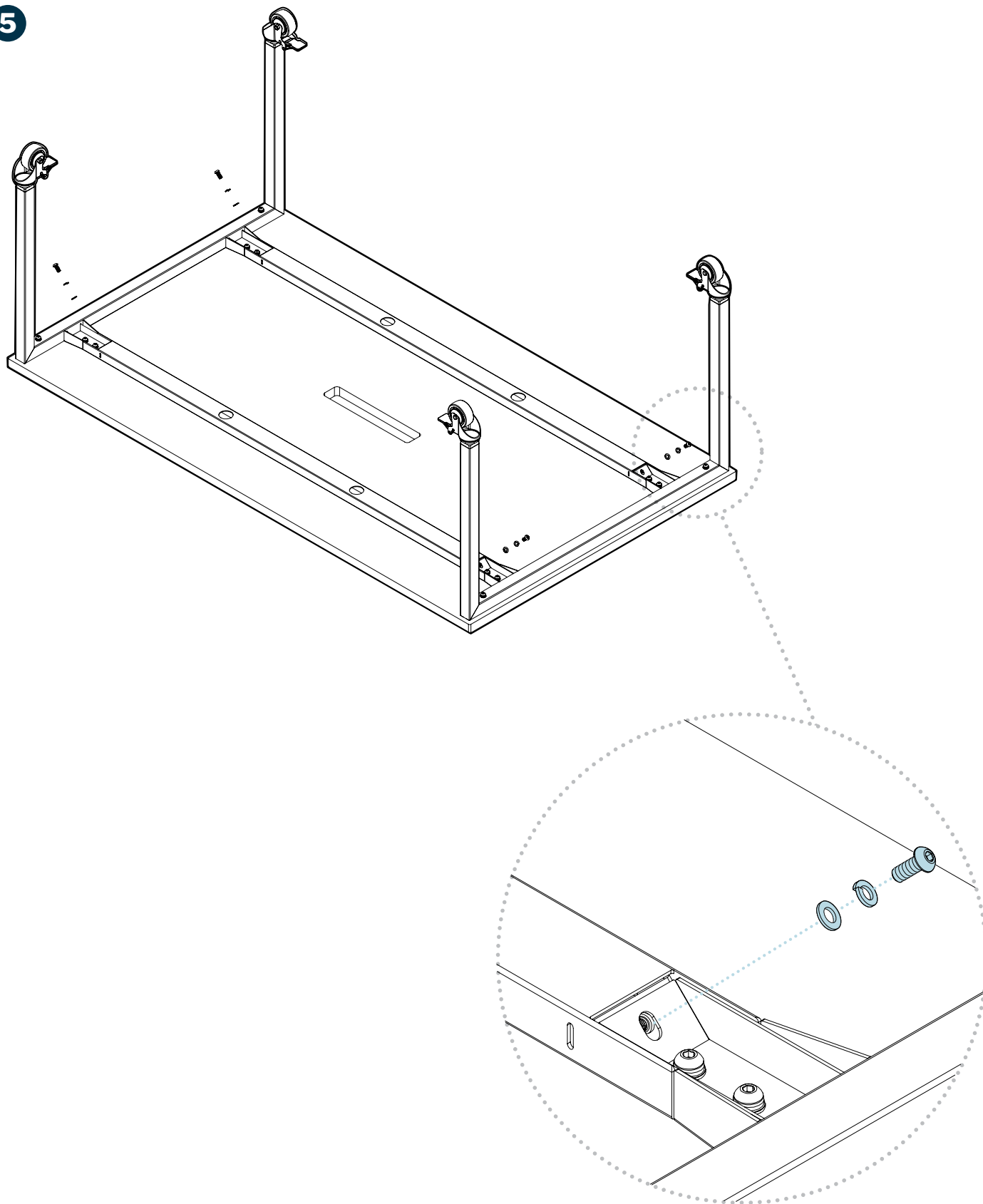

Place a **LOCK WASHER** and then a **FLAT WASHER** onto (4) of the **M8 x 20MM SCREWS**, forming four sets. Insert each set into a slanted opening where the leg frame inserts meet the table top frame. Use the provided **5MM ALLEN KEY** to secure the leg frame inserts to the top **CROSSBARS**.

6

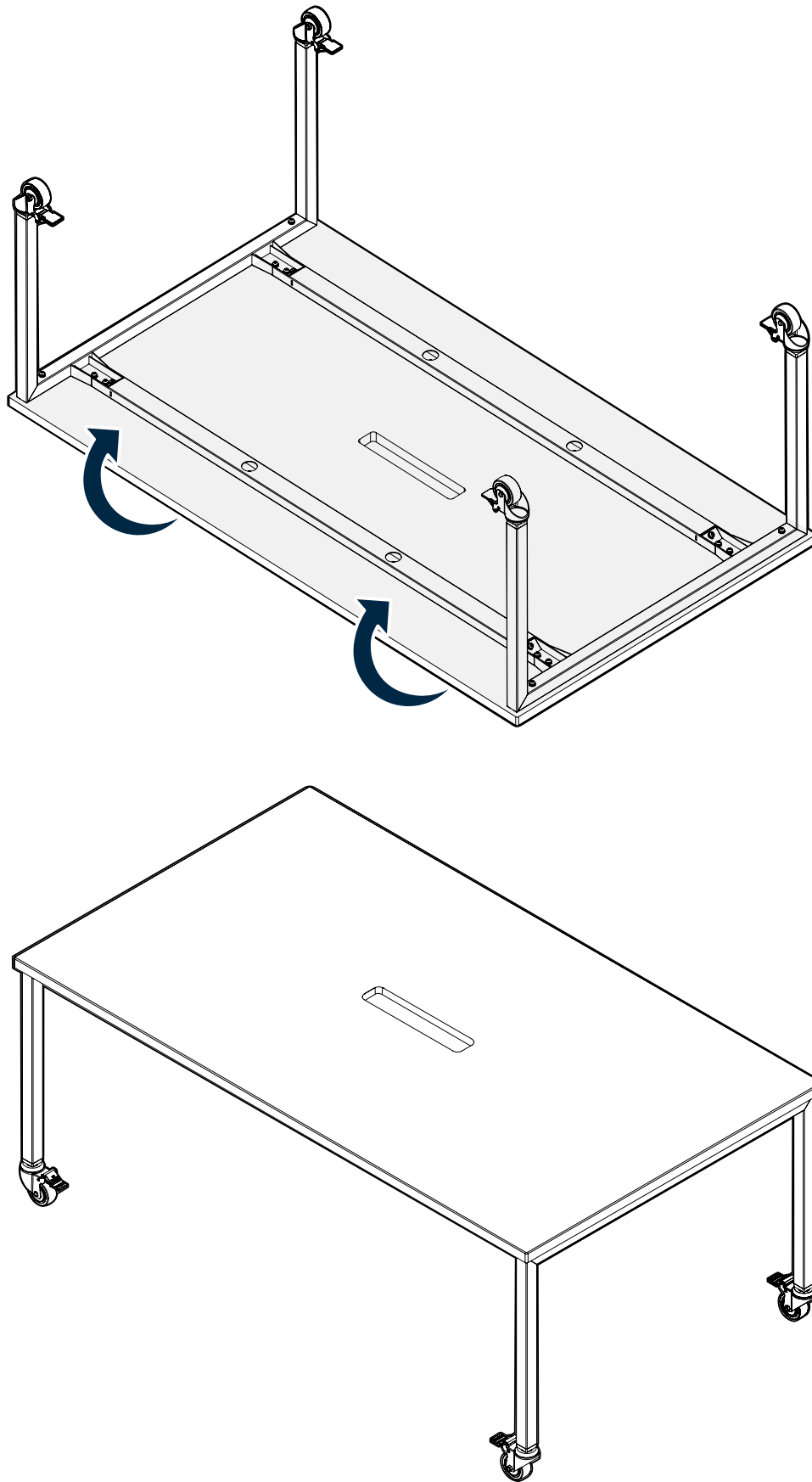

Flatten the box by folding down the outer edges, then tilt the table out of the box. With two people on each end, flip the table. **\*Note: Ensure the casters are locked before flipping the table over.**



7

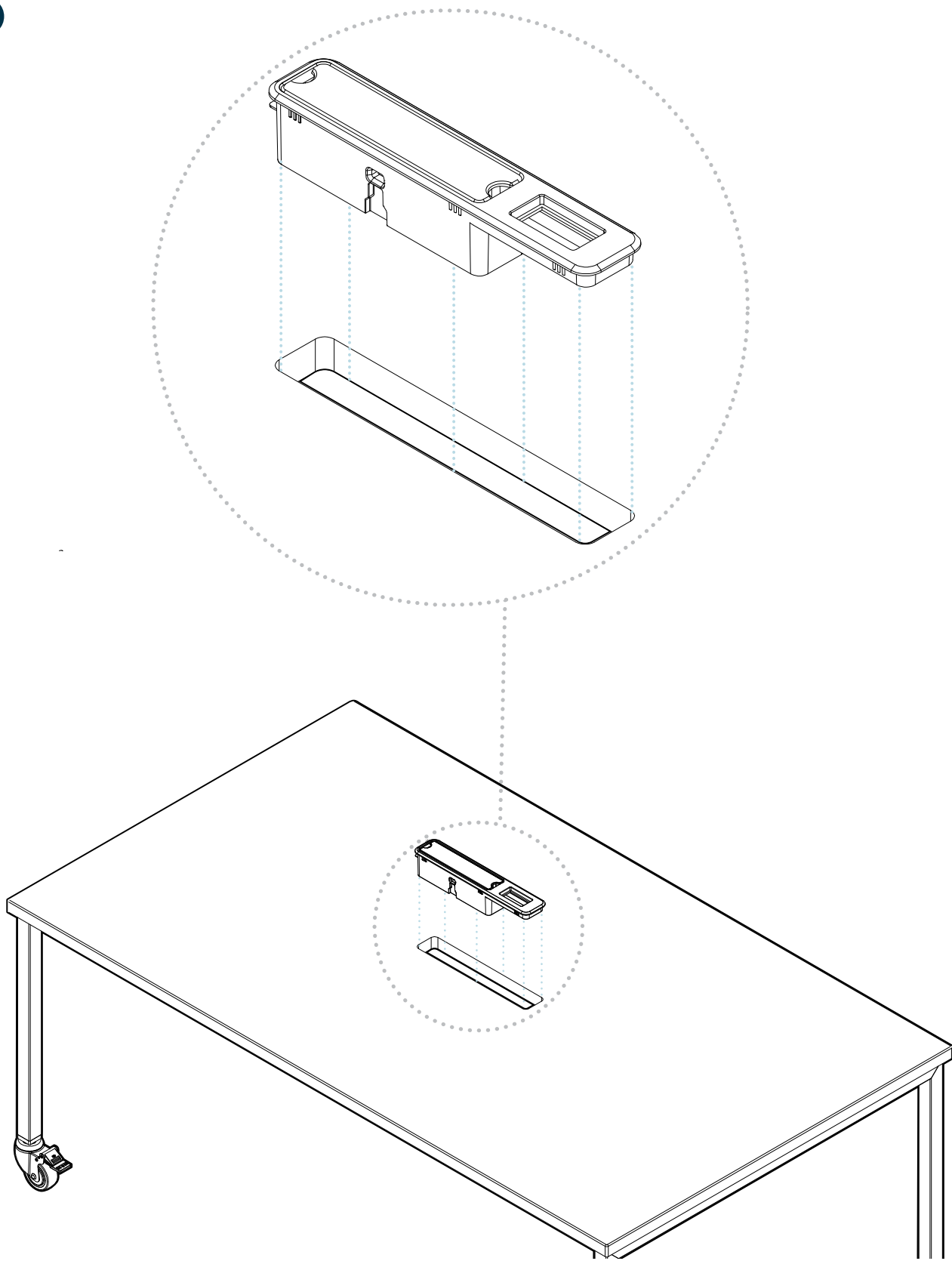

Insert the **GROMMET** into the open hole on the table top.

8

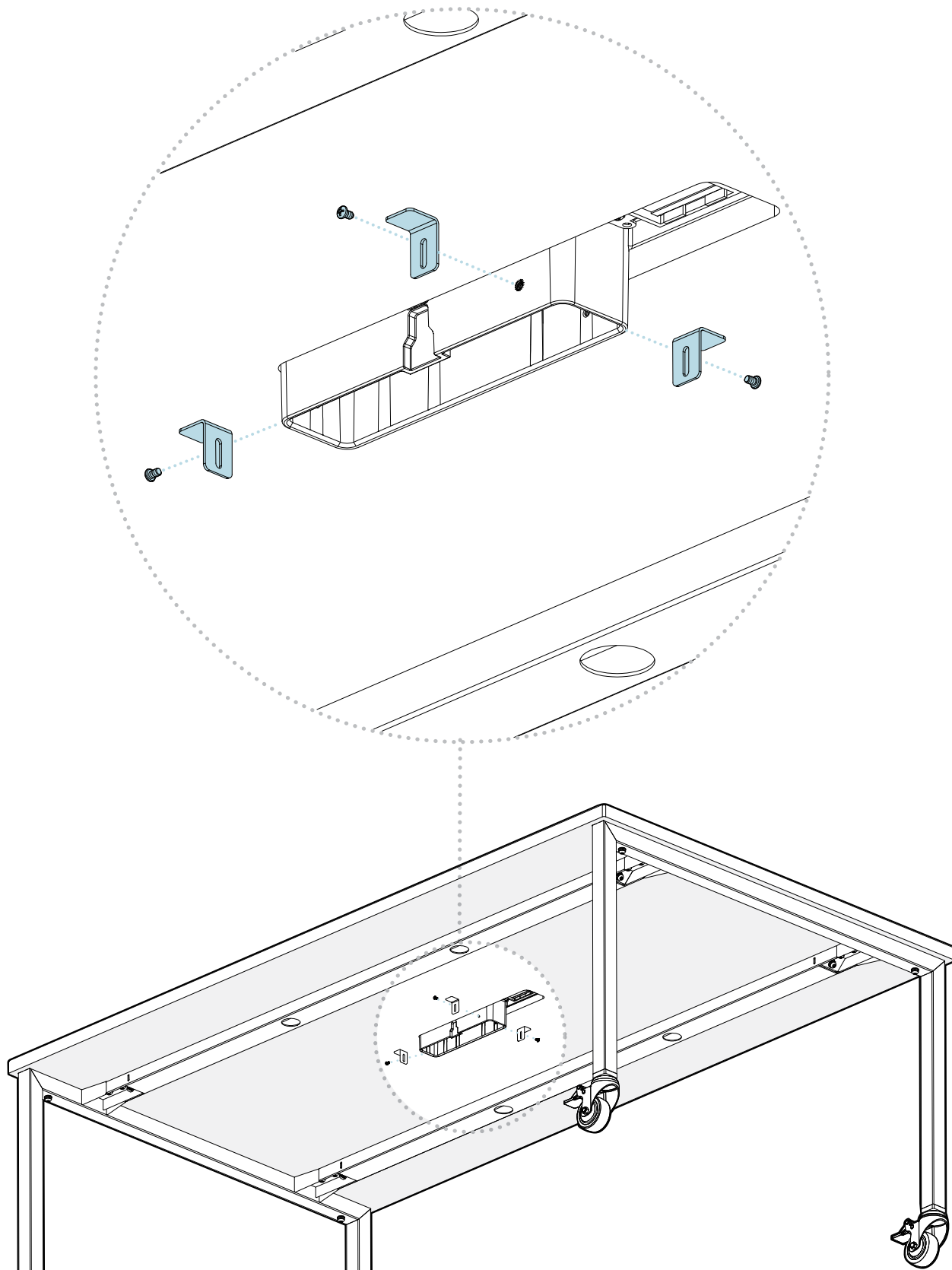

Insert (3) **M4 x 6MM SCREWS** to attach the angle brackets onto the **GROMMET** underneath the table top. The flat surface of the angle brackets should be flush against the bottom of the table top to lock the **GROMMET** in place.

## Power Hub Insertion

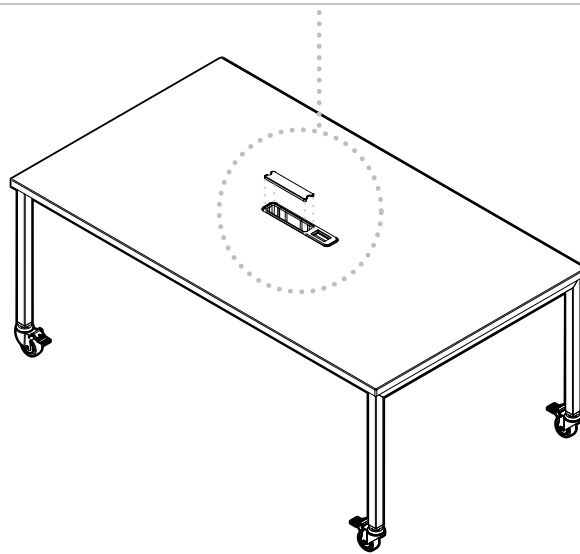
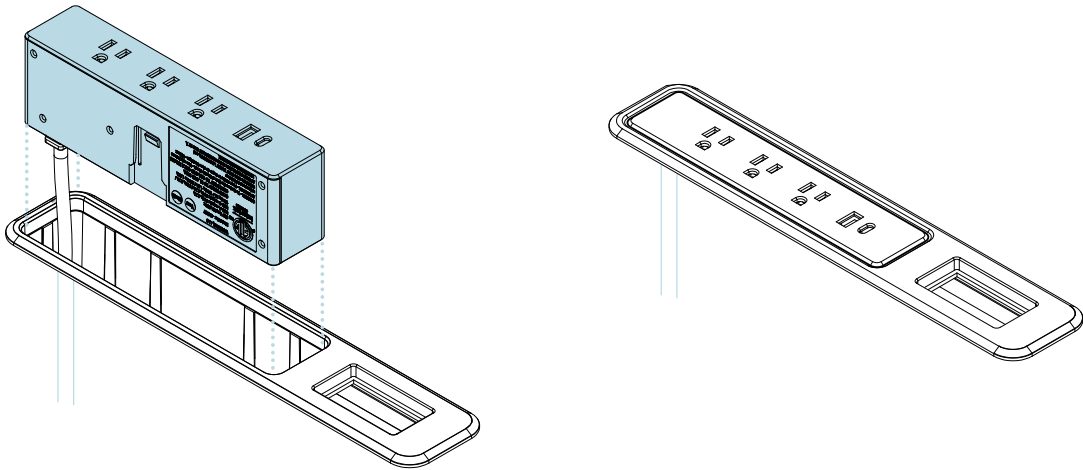
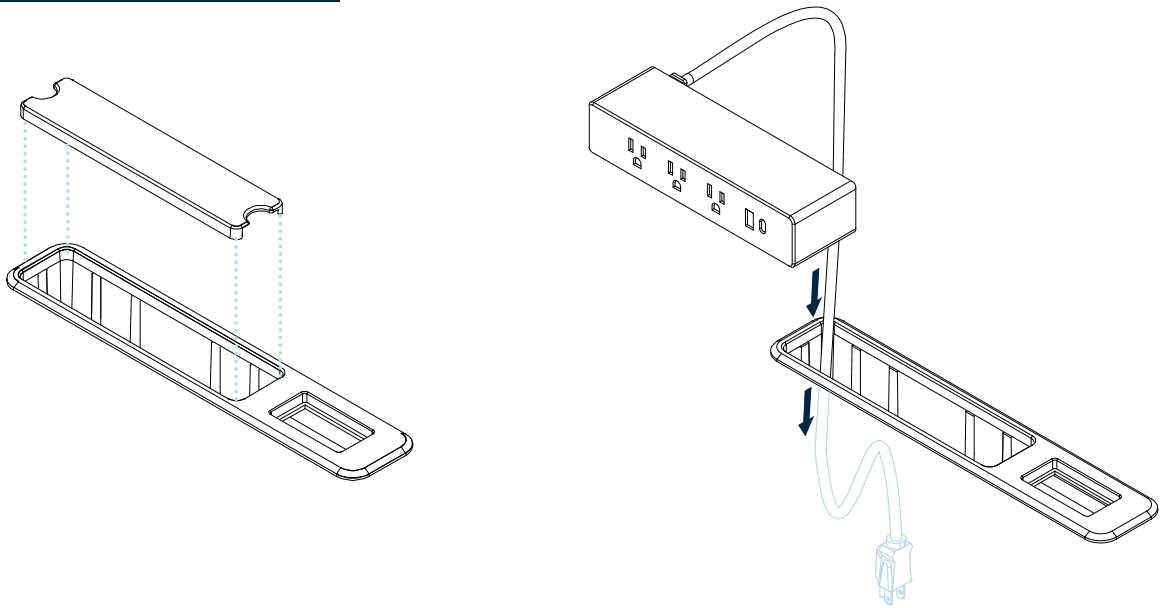

The **Vari Power Hub** can be inserted into the **GROMMET**. Simply slot the cord through the grommet and secure the Power Hub in place. Additional cables can also be routed through the **GROMMET**.

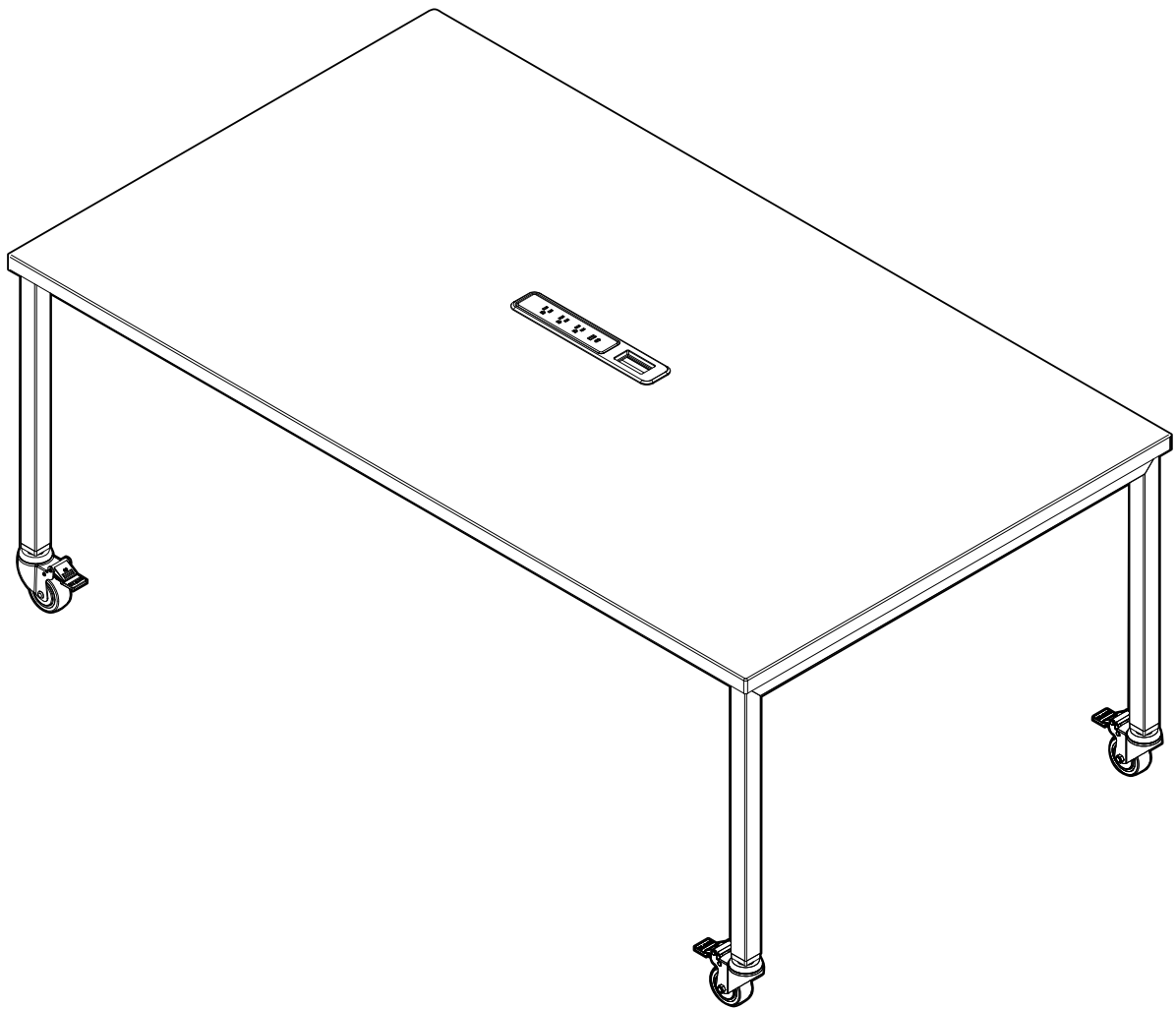

 (800) 207-2587



**WARNING:** To prevent injuries and product failure, do not use this table for standing, climbing, or leaning. Do not use if the table is damaged or incorrectly assembled.